

AD series SERVICE MANUAL

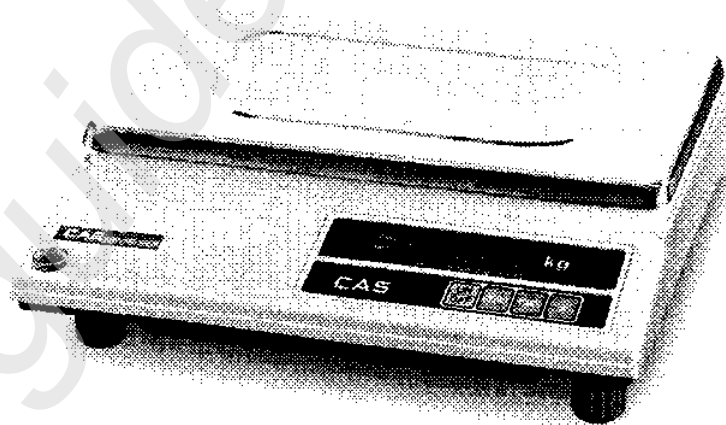

CAS

THE CONTENTS CHAPTER-I THE GENERAL INTRODUCTIONS

A.... PREFACE	4
B.... THE PRECAUTIONS	4
C.... THE SPECIFICATIONS	4
D....SEALING METHOD	5

CHAPTER-II THE CALIBRATIONS

A.... SET THE CALIBRATION MODE	6
B.... THE MODES	7
B.1. THE MODE 1	8
B.2. THE MODE 2	8
B.3. THE MODE 3	8
B.4. THE MODE 4	8
B.5. THE MODE 5	8
C.... THE SPAN CALIBRATION	9
C.1.SET THE CALIBRATION MODE	9
C.2.. ENTRY OF THE MODE 4	9
C.3.SPAN CALIBRATION	10
C.4. CONFIRMATION OF THE SPAN	10
D.... THE SPAN CALIBRATION FROM THE REPAIR	11
D.1.. SET THE CALIBRATION MODE	11
D.2.. CHECK OF THE INITIAL ZERO AND SPAN	11
D.3..THE SPAN CALIBRATION	11
D.4.. CONFIRMATION OF THE SPAN	12
E.... THE SPAN CALIBRATION WITH A PARTIAL LOAD	13
E.1.. SET THE CALIBRATION MODE	13
E.2.ENTRY OF A PARTIAL CALIBRATION	13
E.3.. INPUT OF A PARTIAL LOAD BY PERCENTAGE	13
E.4..THE SPAN CALIBRATION	14
E.5.. CONFIRMATION OF THE SPAN	14

CHAPTER-III THE PART REPLACEMENTS

A.... REPLACEMENT OF THE LOAD CELL	15
A.1.. REPLACEMENT OF THE LOAD CELL	15
A.2. CORRECTION OF THE ECCENTRICITY	15
A.3..THE SPAN CALIBRATION	15
B....REPLACEMENT OF THE ANALOG MODULE	16
B.1..REPLACEMENT OF THE ANALOG MODULE	16
B.2..THE SPAN CALIBRATION FOR THE ANALOG MODULE	16
C....REPLACEMENT OF THE DIGITAL MODULE	16
C.1..REPLACEMENT OF THE DIGITAL MODULE	16
C.2..THE INPUTS FOR THE DIGITAL MODULE	16

CHAPTER-IV THE TRANSFORMER

A.... THE TRANSFORMER	17
-----------------------------	----

CHAPTER-V THE SCHEMATICS AND THE DIAGRAMS

A.1..MAIN CIRCUIT DIAGRAM	19
A.2..DISPLAY CIRCUIT DIAGRAM	20
B...WIRING DIAGRAM	21
C...PARTS LOCATION	22

CHAPTER-VI THE ERROR MESSAGES

A... THE ERROR MESSAGES	23
A.1. ERR 1	23
A.2. ERR 2	23
A.3. ERR 10	23
A.4. ERR 11	23
A.5. ERR 12	23
A.6. ERR 13	23

CHAPTER-VII THE OTHERS

A... FOR THE SERIAL INTERFACE	24
A.1..THE COMMUNICATION AGREEMENTS	24
A.2..THE WIRE CONNECTIONS	24
A.3..THE PROTOCOL	25
A.4. THE DATA TRAINS	25
B...EXPLODED VIEW	27
C... FULL PARTS LIST	28

CHAPTER-VIII APPENDIX-I

A... INPUT CODES FOR THE DIGITAL MODULE	32
A.1 THE ALTERNATIVE KEY FUNCTIONS	32
A.2 INPUTS FOR WEIGH CONDITION CODES	32
A.3 THE SPAN CALIBRATION	33

CHAPTER-I THE GENERAL INTRODUCTIONS

A. PREFACE

Thank you for the purchasing of CAS scale.

This scale has been designed with CAS reliability, under rigid quality control and with outstanding performance.

Your departments can enjoy with this high quality reliable CAS product.

We believe that your needs will be satisfied and you will have proper reliability with in variable weight.

This manual will help you with proper operations and care of the AD series.

Please keep it handy for the future references.

B. THE PRECAUTIONS

1. Check the power voltage.
2. Place the scale on a flat and stable surface.
3. Level the scale with four adjusters.
Bubble of the level should be centered.
4. Plug into AC outlet 10 minutes before operations.
5. Keep the scale away from strong E.M.I, noises.
6. This scale must be installed in a dry and liquid free environment.
7. Do not expose the scale to sudden temperature change.
8. Do not expose the scale to sudden impact.

C. THE SPECIFICATIONS

MODEL	A D - 1				
CAPACITIES	2.5 x 0.0005 kg	3 x 0.001 kg	5 x 0.001 kg	15 x 0.005 kg	30 x 0.010 kg
DISPLAY: WEIGHT	Vaccum Flourscent Display 5 DIGIT				
DISPLAY DESIGNATORS	ZERO, TARE, kg, and lb				
MAXIMUM TARE	- 999.5 g	- 3.000 kg	- 5.000 kg	- 9.995 kg	- 9.990 kg
POWER SOURCE	110V, 220V, 240V / 50Hz, 60Hz				
POWER CONSUMPTION	APPROX. 10W				
PLATTER SIZE (mm)	340(W) X 215(D)				
PRODUCT SIZE (mm)	350(W)X325(D)X495(H)				

Notice : specifications are subject to change for improvement without notice.

D. SEALING METHOD

SEALING METHOD

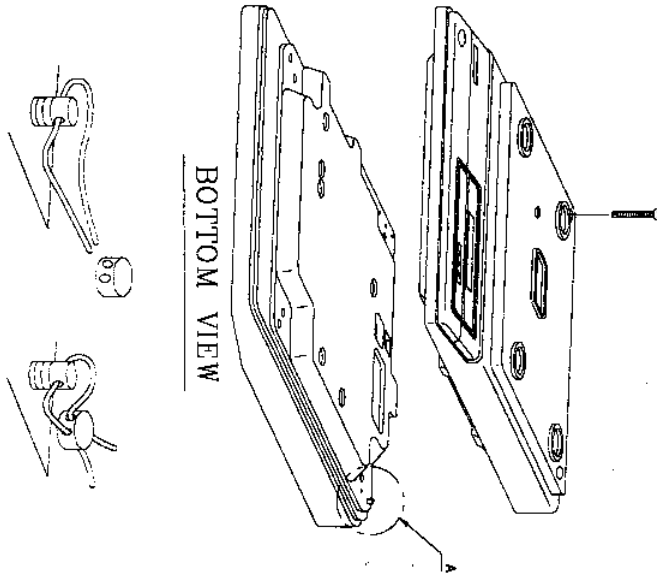

BOTTOM VIEW

AD SERIES CAL SEALING

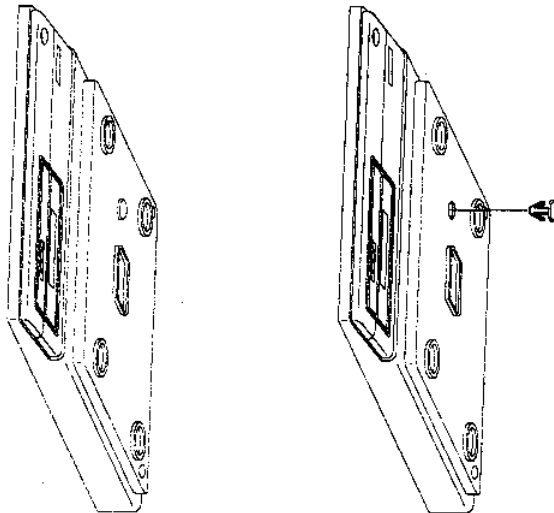

CHAPTER-II THE CALIBRATIONS

A. SET THE CALIBRATION MODE

The CAL switch is located underneath of the hole left of the upper case.

1. Remove a seal cover.
2. Slide CAL switch to the CAL position.

C A L



normal mode

C A L

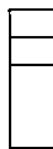

calibration mode

3. Plug into the AC outlet.

-> The display shows "CAL" three times.

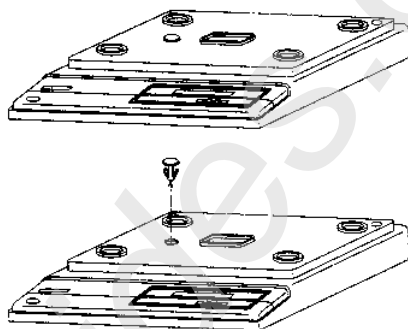

REMOVING CAL SEALING

B. THE MODES

This scale *has* 5 modes for set of weighing condition and for set of the span calibration.
These 5 modes are described as below.

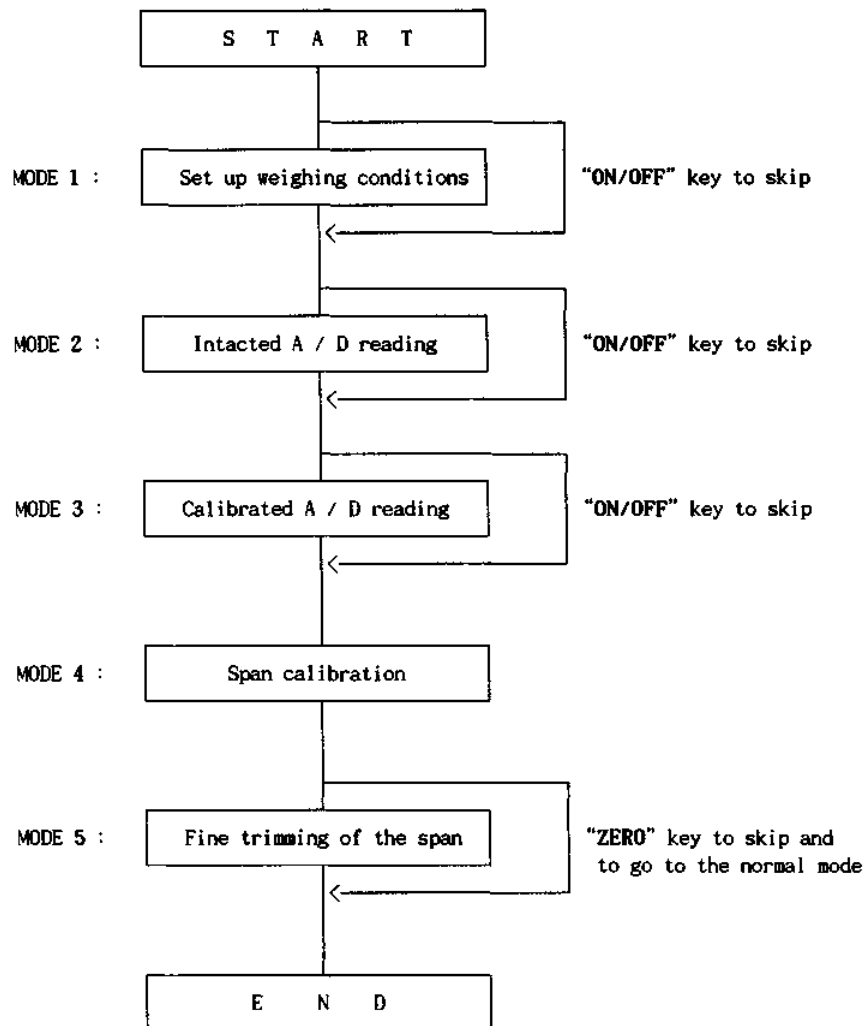

B.1 THE MODE 1

In this mode 1, a various weighing conditions can be set.
Weighing conditions for capacity, external resolution, and decimal point etc.
In this mode, below three keys have an alternative functions respectively.

*	(or kg/lb) (hold)	=>	Numeric increment
---	----------------------	----	-------------------

TARE		=>	Digit shift
------	--	----	-------------

ZERO		=>	Enter
------	--	----	-------

* For entire sets of weighing conditions, please refer to the APPENDIX I.

B.2 THE MODE 2

In this mode 2, intacted A/D reading is shown on the display.
This intacted A/D reading is necessary to check an initial zero point and to check a span range both, when either a load cell was replaced or an analog module was replaced.
Unless above both replacement, skip to this mode 2 by pressing the 'ON/OFF' key.

B.3 THE MODE 3

In this mode 3, a calibrated A/D reading is shown on the display.
This mode helps to do a fine span trimming without span calibration(MODE 4).

B.4 THE MODE 4

In this mode 4, an actual span of the scale is calculated by digital calibration method. The sign "ULOAD", means empty the platter, "LOAD" means, load a full weight on the platter.

* If you want to quit this span calibration, press the "ZERO" key while either "ULOAD " or "LOAD" is shown on the display.

B.5 THE MODE 5

Finally in this mode 5, a fine span trimming is obtained after a span calibration(MODE 4)

C. THE SPAN CALIBRATION MODE 4) C. 1 SET THE

CALIBRATION MODE

The CAL switch is located underneath of a hole left of the upper case.

1. Remove a seal plate.
2. Slide CAL switch to the CAL position.

C A L



normal mode

C A L

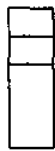

calibration mode

3. Plug into the AC outlet.
-> The display shows "CAL" three times.

C.2 ENTRY OF THE MODE 4

Enter to span calibration mode as below

Key operations

ON/OFF

=>

Display

C SET

=>

1-XX

Mode 1

ON/OFF

=>

X, XXX

Mode 2

ON/OFF

=>

X, XXX

Mode 3

ON/OFF

=>

Blank

Blank

ON/OFF

=>

ULOAD

Mode 4

C.3 SPAN CALIBRATION

In this MODE 4, "ULOAD" is shown on the display.

1. Press the "ON/OFF" key,
-> The display shows a count down 9 to 0. -> "LOAD" is shown on the display.
2. Load a full weight on the platter gently.
3. Press the "ON/OFF" key,
-> The display shows a count down again, -> The display shows "End" and be blanked.
4. Remove a full load from the platter.

*If you want to quit this span calibration, press the "ZERO" key while either "ULOAD" or "LOAD" is shown on the display.

With above operations, the span calibration is finished, and following paragraph A. 4 guides to confirm the span and to do fine trimming for more accurate weighing.

However when fine trimming is not needed, press the "ZERO" key to skip following MODE 5 and exit to the normal mode.

C.4 CONFIRMATION OF THE SPAN(MODE 5)

This mode 5 is only available after performance of a previous span calibration(mode 4).

1. Press the "TARE" key,
-> The display shows the initial zero point.
2. Press the "ZERO" key to read a span(net weight),
-> The display shows "0".
3. Load a full weight on the platter gently.
Unless the display has 30,000 +/-1, for more accurate weighing, perform a fine trimming.
4. If a span is bigger than 30,000, press the "*" or "kg/lb" key twice for a decreasing and less than 30,000, press the "*" or "kg/lb" key and press the "TARE" key for an increasing.
Whenever you press these keys, a count can be changed.
5. At the end of fine trimming, press the "ON/OFF" key.
6. Press the "ZERO" key to exit and go to the normal mode.
-> Weight display shows "Err 2", but actually this error message is not a real error, it prompts only return CAL switch to the normal position.
7. Return the CAL switch to the normal position(initial position).

D. THE SPAN CALIBRATION FROM REPAIR D.1 SET THE

CALIBRATION MODE

The CAL switch is located underneath of a hole left of the upper case.

1. Remove a seal plate.



3. Plug into the AC outlet.

-> The display shows "CAL" three times.

D.2 CHECK THE INITIAL ZERO AND SPAN(MODE 2)

2. Slide CAL switch to the CAL position.

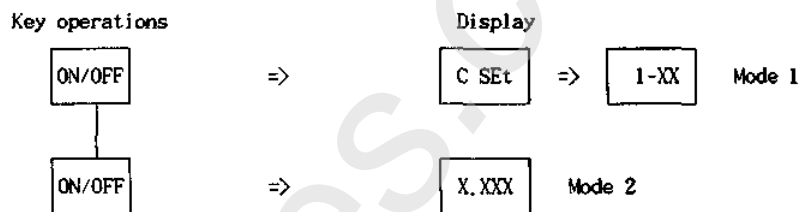

1. Press the "TAKE" key to check the initial zero point.
The initial zero point must be smaller than 20,000 counts.
2. Press the "ZERO" key to check the span.
3. Load a full weight on the platter gently.
The span must be bigger than 30,000 counts.
4. Remove a full load from the platter.
5. At the end of both checks, press the "ON/OFF" key three times to go to the MODE 4.

D.3 THE SPAN CALIBRATION(MODE 4)

In this MODE 4, the display is shown "ULOAD".

1. Press the "ON/OFF" key,
-> The display shows a count down 9 to 0. -> "LOAD" is shown on the display.
2. Load a full weight on the platter gently.
3. Press the "ON/OFF" key,
-> The display shows a count down again, -> The display shows "End" and be blanked.
4. Remove a full load from the platter.

*If you want to quit this span calibration, press the "ZERO" key while either "ULOAD" or "LOAD" is shown on the display.

With above operations, the span calibration is finished, and following paragraph B.4 guides to confirm the span and to do a fine trimming for more accurate weighing.

However when fine trimming is not needed, press the "ZERO" key to skip following MODE 5 and exit to the normal mode.

D.4 CONFIRMATION OF THE SPAN(MODE 5)

This mode 5 is only available after a performance of previous span calibration(mode 4).

1. Press the "TARE" key,
-> The display shows the initial zero point.
2. Press the "ZERO" key to read a span(net weight),
-> The display shows "0".
3. Load a full weight on the platter gently.
Unless the display has 30,000 +/-1, for more accurate weighing, perform fine trimming.
4. If a span is bigger than 30,000, press the "*" or "kg/lb" key twice for a decreasing and less than 30,000, press the "*" or "kg/lb" key and touch the "TARE" key for an increasing. Whenever you press these keys, a count can be changed.
5. At the end of fine trimming, press the "ON/OFF" key.
6. Press the "ZERO" key to exit and go to the normal mode.
-> Weight display shows "Err 2", but actually this error message is not a real error, it prompts only return CAL switch to the normal position.
7. Return the CAL switch to the normal position(initial position).

E. THE SPAN CALIBRATION WITH A PARTIAL LOAD

For the purpose of convenience, a partial span calibration is provided.

E.1 SET TO THE CALIBRATION MODE

The CAL switch is located underneath of a hole left of the upper case.

1. Remove a seal plate.
2. Slide CAL switch to the CAL position.

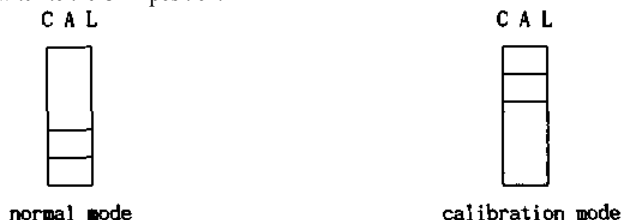

3. Plug into the AC outlet.
-> The display shows 'CAL' three times.

E.2 ENTRY OF A PARTIAL CALIBRATION

Enter to partial span calibration mode as below

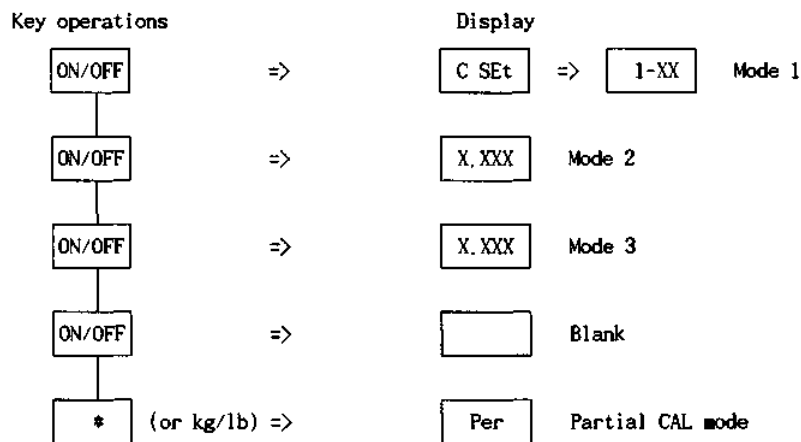

E.3 INPUT A PARTIAL LOAD BY PERCENTAGE

In this mode, below three keys have an alternative functions respectively.

* (or kg/lb) => Numeric increment

TARE => Digit shift

ZERO => Enter

Enter a desired partial load by percentage using above three keys. Press the "ON/OFF" key to move to MODE 4.

E.4 THE SPAN CALIBRATION

In this MODE 4, "ULOAD" is shown on the display.

1. Press the "ON/OFF" key,
-> The display shows a count down 9 to 0. -> "LOAD" is shown on the display.
2. Load a full weight on the platter gently.
3. Press the "ON/OFF" key,
-> The display shows a count down again, -> The display shows "End" and be blanked.
4. Remove a full load from the platter.

* If you want to quit this span calibration, press the "ZERO" key while either "ULOAD " "LOAD" is shown on the or display.

With above operations, the span calibration is finished, and following paragraph C. 5 guides to confirm the span and to do a fine trimming for more accurate weighing.

However when fine trimming is not needed, press the "ZERO" key to skip following MODE 5 and exit to normal mode.

E.5 CONFIRMATION OF THE SPAN(MODE 5)

This mode 5 is only available after a performance of previous span calibration(mode 4).

1. Press the "TARE" key,
-> The display shows the initial zero point.
2. Press the "ZERO" key to read a span(net weight),
-> The display shows "0".
3. Load a full weight on the platter gently.
Unless the display has 30,000 +-1, for more accurate weighing, perform fine trimming.
4. If a span is bigger than 30,000, press the "*" or "kg/lb" key twice for a decreasing and less than 30,000, press the "*" or "kg/lb" key and touch the "TARE" key for an increasing.
Whenever you press these keys, a count can be changed.
5. At the end of fine trimming, press the "ON/OFF" key.
6. Press the "ZERO" key to exit and enter to normal mode.
-> Weight display shows "Err 2", but actually this error message is not a real error, it prompts only return CAL switch to the normal position.
7. Return the CAL switch to the normal position(initial position).

CHAPTER-III THE PART REPLACEMENTS

A. REPLACEMENT OF THE LOAD CELL A.I REPLACEMENT OF THE

LOAD CELL

- A.1.1 Remove the platter and disassemble the upper case.
- A. 1.2 Remove the platform on the load cell with a hex wrench.
- A.1.3 Disconnect a connector wire of the load cell from the P.C.B.
- A.1.4 Remove the load cell from the body.
- A.1.5 Replace the load cell by a new one.
- A. 1.6 Connect a connector wire of the load cell to the P.C.B.
- A.1.7 Place the platform on the load cell.

A.2 CORRECTION OF THE ECCENTRICITY

- A.2.1 Set the calibration mode. A.2.2 Set the MODE 2. (CHAPTER II, D.2)
- A.2.3 Rezero the display by pressing the "ZERO" key, if it is needed. A.2.4 Put a quarter of the full weight on the platter by turns as shown in below.

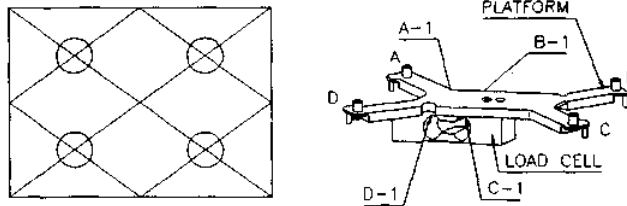

- A.2.5 File each corner which has a less output than the others.
And check each point is within ± 1 count tolerance with % of a full load.

A.3 THE SPAN CALIBRATION

Refer to the SPAN CALIBRATION FROM REPAIR in the Chapter II.

B REPLACEMENT OF THE ANALOG MODULE

B.1 REPLACEMENT OF THE ANALOG MODULE

- B.1.1 Remove platter and the upper case.
- B.1.2 Take a main circuit board out on the body.
- B.1.3 Desolder the analog module pins(11 points) on main board.
- B.1.4 Replace the analog module(CAM 01) by a new one.
- B.1.5 Install a main board on the body.
- B.1.6 Reassemble upper case and platter.

B.2 THE SPAN CALIBRATION FOR THE ANALOG MODULE

Refer to the SPAN CALIBRATION FROM REPAIR in the CHAPTER-III.

C REPLACEMENT OF THE DIGITAL MODULE

C.1 REPLACEMENT OF THE DIGITAL MODULE

- C.1.1 Remove the platter and the upper case.
- C.1.2 Take a main circuit board out on the body.
- C.1.3 Desolder the digital module pins(48 points) on main board.
- C.1.4 Replace the digital module(CDM 01) by a new one.
- C.1.5 Install a main board on the body.
- C.1.6 Reassemble upper case and platter.

C.2 THE INPUT FOR THE DIGITAL MODULE

In the digital module, it has a nonvolatile memory and contains a factor for a digital span calculations and the weighing conditions. Therefore all those input procedures must be performed. Refer to APPENDIX-I.

CHAPTER-IV THE TRANSFORMER

A. THE TRANSFORMER

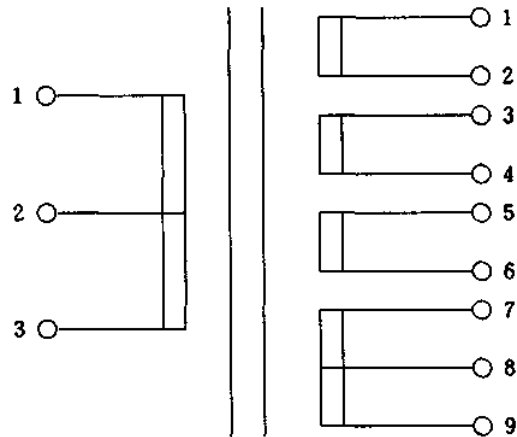

QUALITY OF LEAD WIRE AND LENGTH						
	NO.	COLOR	WIRE LENGTH	TREATMENT (mm)	mA	V
INPUT	1	WHITE	200 mm	± 10		0
	2	BROWN	"	"		110
	3	RED	"	"		220
OUTPUT	1	GRAY	250 mm	"	100	16.5
	2	PURPLE	"	"		
	3	BLUE	"	"		
	4	GREEN	"	"	100	8.8
	5	YELLOW	"	"		
	6	ORANGE	"	"	50	29
	7	RED	"	"		
	8	BROWN	"	"	700	1.65
	9	BLACK	"	"	0	0
					700	1.65

* CORE : 48 × 25 mm

* 50Hz / 60Hz

CHAPTER-VI

THE SCHEMATICS AND THE DIAGRAMS

A.1 MAIN CIRCUIT DIAGRAM

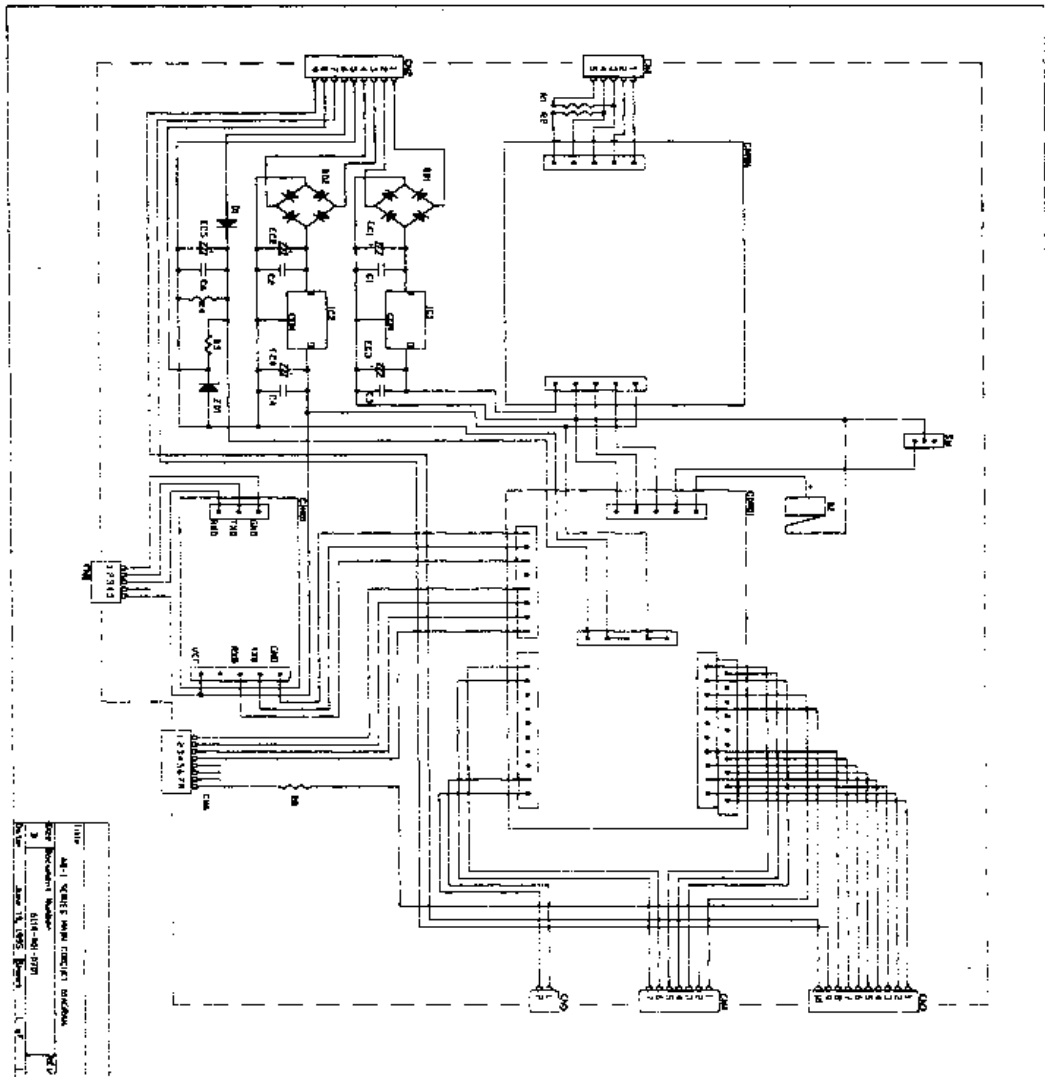

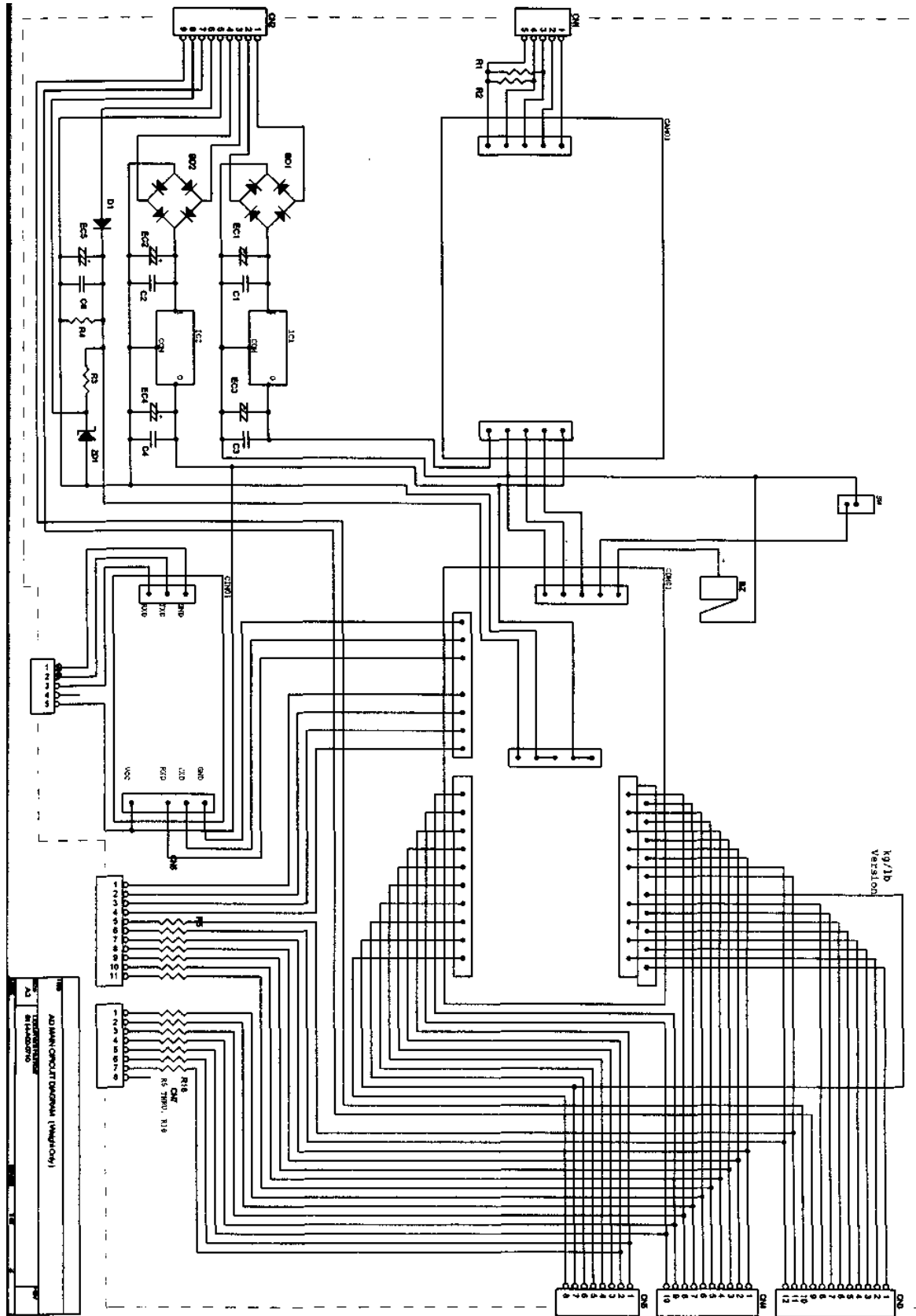

A.2 DISPLAY CIRCUIT DIAGRAM

REV:00

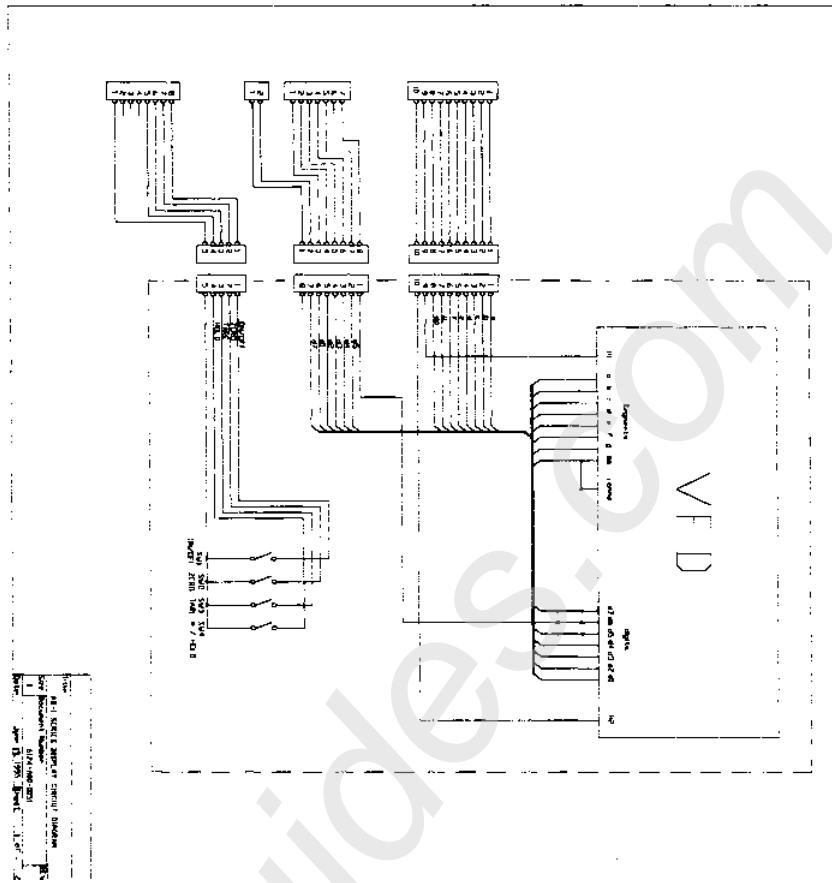

B. WIRING DIAGRAM

REV:00

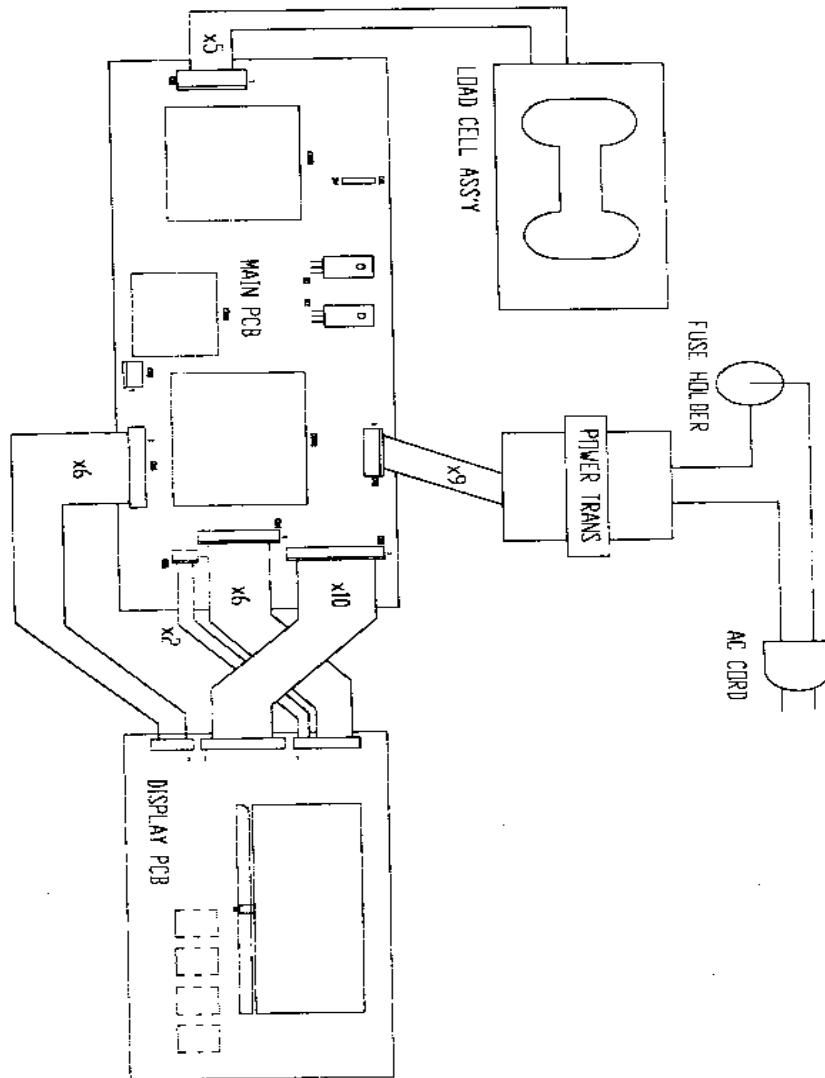

C. PARTS LOCATION

REV:00

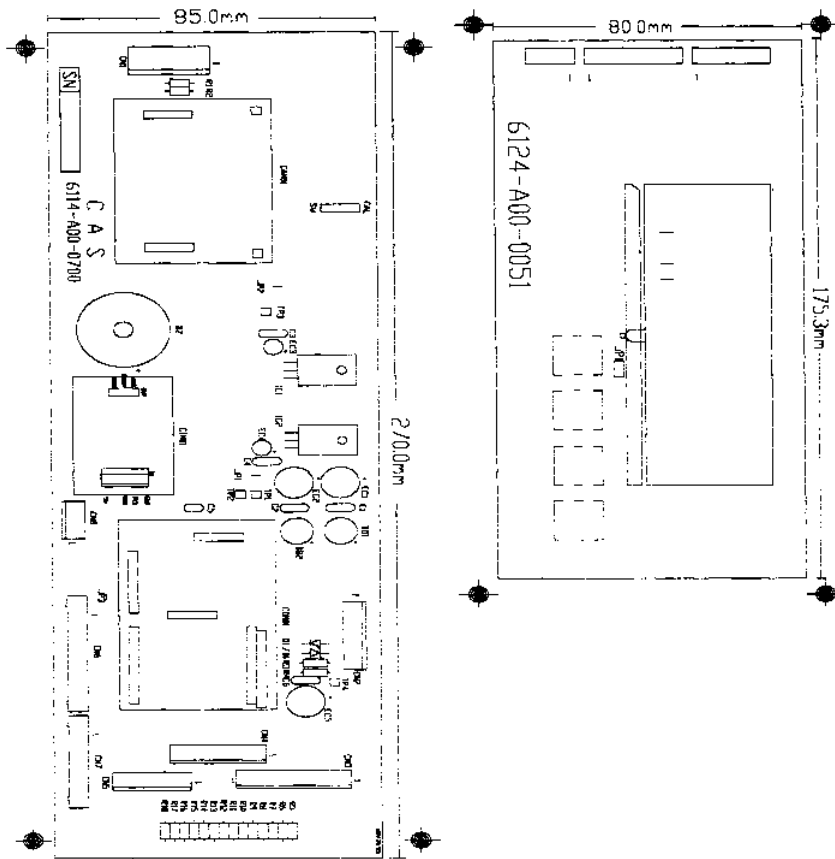

CHAPTER-VI THE ERROR MESSAGES

A. THE ERROR MESSAGES

These error messages will guide you to do a quick troubleshooting.

A.1 'Err 1'

The "Err 1" can be happen when a current zero point has shifted from the last span calibration.

A.1.1 If a dead load of load cell has changed.

To use with a different dead load from with a last span calibration, the span calibration must be done before use.

However, do not exceed of a dead load bigger than 20,000 counts in calibration mode 5. A. 1.2 If the contact resistance of a load cell connector is poor. Clean the load cell connector or replace it. A. 1.3 If the zero point of a load cell has

shifted.

Replace the load cell. A. 1.4 If the analog module has failed.

Replace the analog module.

For ordering, call for the name CAM 01.

A.2 'Err 2'

A.2.1 The "Err 2" is not a real error, only it prompts return CAL switch to the normal position.

A.3 'Err 10'

A.3.1 The "Err 10" means a failure of the analog module. Replace the analog module by a new one. For ordering, call for the name CAM 01.

A.4 'Err 11'

A.4.1 The "Err 11" means a writing error of the internal nonvolatile memory.

To recognize this error, be sure to voltages on the circuits and do a calibration procedures.

Nevertheless, the display shows same "Err 11" replace the digital module.

For ordering, call for the name COM 01 version 2.

A.5 'Err 12'

A. 5.1 The "Err 12" warns that the scale has lost of the parameters for under weighing regulations or has lost of the factors for a digital span calculation. To recover this, enter each condition codes again. Refer to APPENDIX-I.

A.6 'Err 13'

A.6.1 The "Err 13" means the soft key(s) code has(have) lost.

To recover from this(these) error(s), find the which key(s) has(have) lost of the soft keycode(s) and then re-enter the soft key code(s) on it(them).

Refer to APPENDIX-I.

CHAPTER-VII THE OTHERS

A. FOR THE SERIAL INTERFACES

THE PROTOCOLS FOR THE CAS STANDARD SERIAL INTERFACE

THIS IS HALF-DUPLEX COMMUNICATION RS-232C.

A. 1 THE COMMUNICATION AGREEMENTS

1. BAUD RATE -> 9,600 EPS
2. DATA BIT -> 8 BIT
3. STOP BIT -> 1 BIT
4. PARITY BIT -> NO
5. COMMUNICATION LEVEL -> RS-232C LEVEL
6. DATA FORMAT -> ASCII
7. THE COMMAND DEFINITIONS
 - 7-1. "ENQ" -> 05H
 - 7-2. "ACK" -> 06H
 - 7-3. "NAK" -> 15H
 - 7-4. "SOH" -> 01H
 - 7-5. "STX" -> 02H
 - 7-6. "ETX" -> 03H
 - 7-7. "EOT" -> 04H
 - 7-8. "DC1" -> 11H
 - 7-9. "DC2" -> 12H
 - 7-10. "DC3" -> 13H
 - 7-11. "DC4" -> 14H

A.2 THE WIRE CONNECTIONS

A.2.1 THE WIRE CONNECTIONS OF THE D-SUB 9 PIN CONNECTOR OF A COMPUTER SIDE

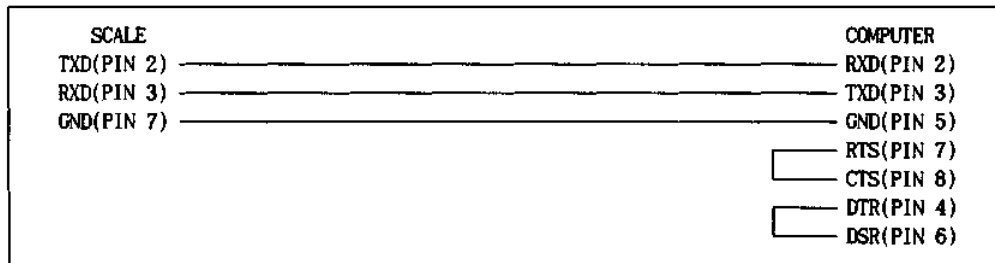

A. 2.2 THE WIRE CONNECTIONS OF THE D-SUB 25 PIN CONNECTOR OF A COMPUTER SIDE

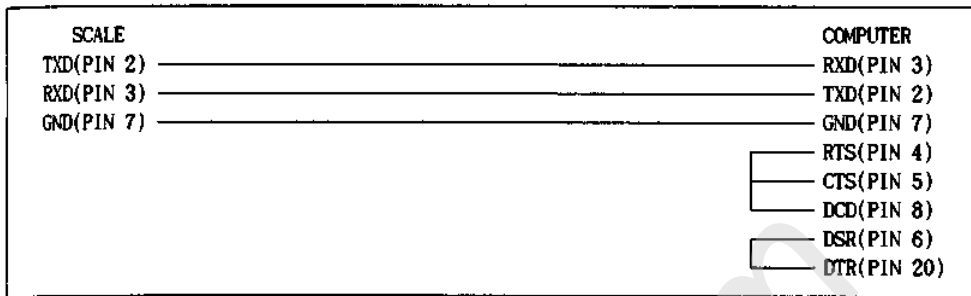

A. 3 THE PROTOCOL

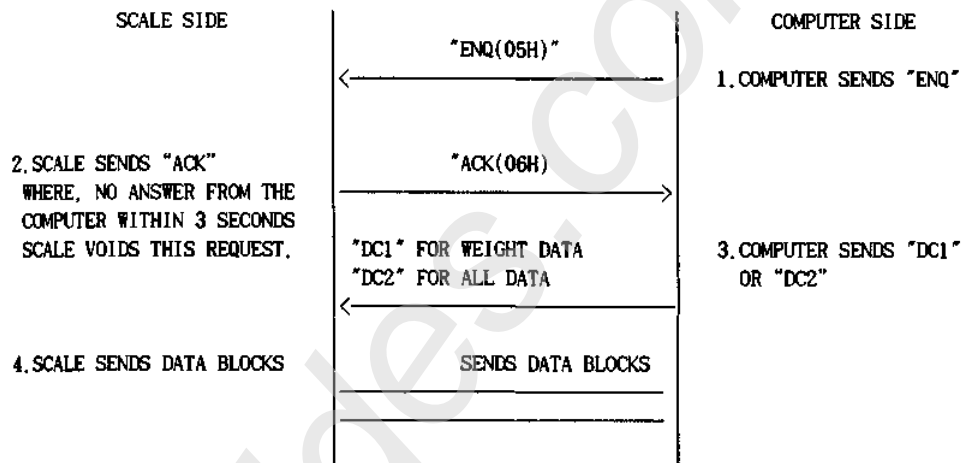

A. 4. THE DATA TRAINS

1. THE DATA TRAINS FOR THE "DC1"

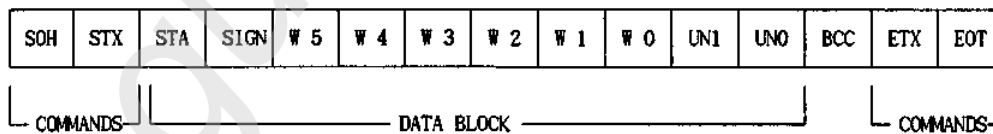

REMARKS: .STA -> A WEIGHING STATUS OF THE SCALE
SCALE IS STABLE -> "S", NOT STABLED -> "U". SIGN -> SIGN OF
THE WEIGHT DATA
ZERO AND POSITIVE WEIGHT -> "", NEGATIVE WEIGHT -> "-"
OVER LOAD -> "F". W5 THROUGH W0 ->
WEIGHT DATA
BUT ALL "F"s WHEN THE SCALE IS PUT ON OVER LOAD. UNI
THROUGH UNO -> UNIT OF WEIGHT(kg OR lb). BCC -> BLOCK CHECK
CHARACTER
BCC IS CREATED BY EXCLUSIVE ORDERED OF A DATA BLOCK.

2. THE DATA TRAINS FOR THE "DC2"

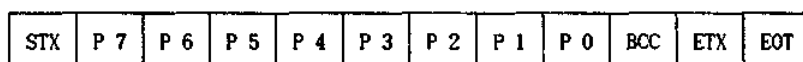
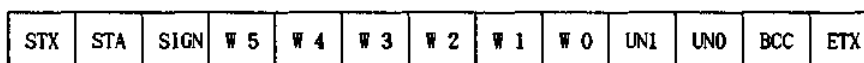
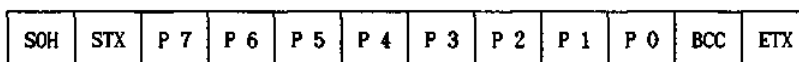

REMARKS : .STA -> A WEIGHING STATUS OF THE SCALE
SCALE IS STABLE -> "S" , NOT STABLED -> "U" .SIGN ->SIGNS OF THE WEIGHT
DATA
ZERO AND POSITIVE WEIGHT -> " " , NEGATIVE WEIGHT -> "-" ,
OVER LOAD -> "F" . P7 THROUGH PO -> PRICE DATA
IF THE OVER FLOW IS HAPPEN IN PRICE, ALL "F"s WILL FILL TO DATA BLOCK
OF THE PRICE. .W5 THROUGH WO -> WEIGHT DATA
BUT ALL "F"s WHEN THE SCALE IS PUT ON OVER LOAD. . UNI THROUGH UNO -> UNIT
OF WEIGHT(kg OR lb) .BCC -> BLOCK CHECK CHARACTER
BCC IS CREATED BY EXCLUSIVE ORDERED OF EACH DATA BLOCKS.

B. EXPLODED VIEW(MECHANICAL PART)

REV : 00

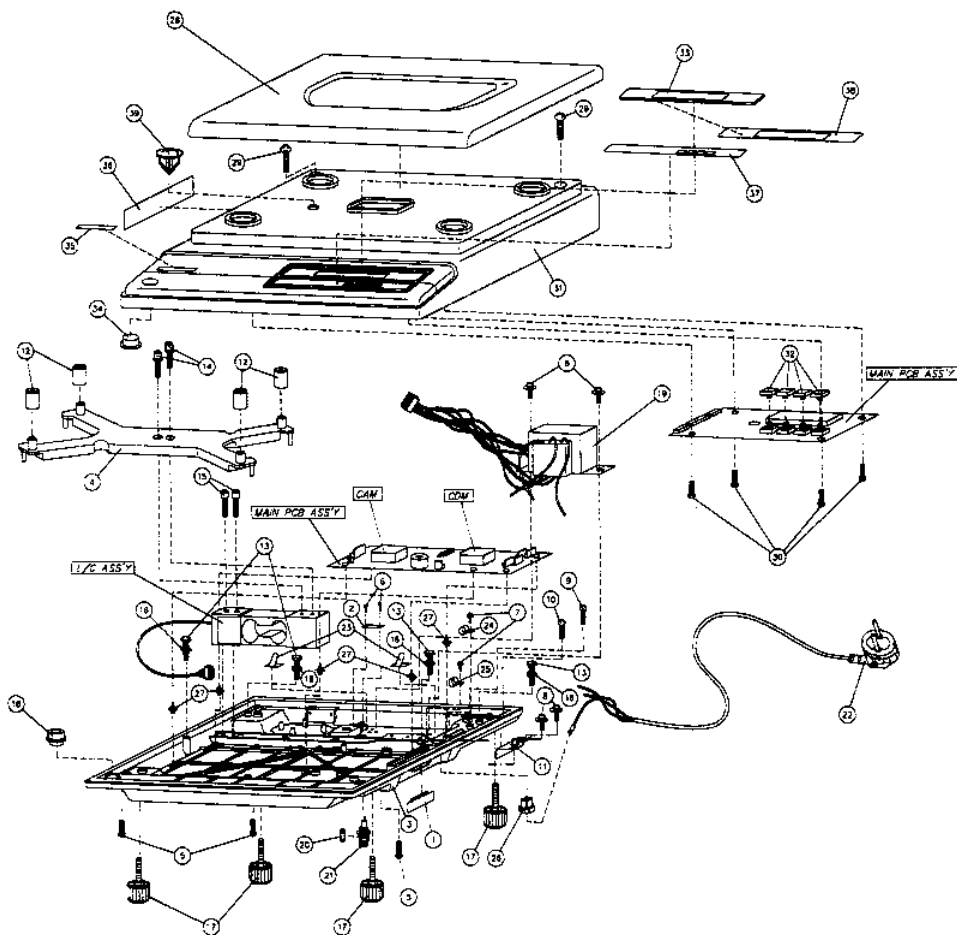

C. FULL PARTS LIST

REV : 00

NO	MAT'L NEW CODE	PART NAME	SPECIFICATION	UNIT	Q'TY	LOCATION
ASS'Y MAIN PCB						
1	1502-A00-0308-0	MACHINE SCREW (PH)	M3*8	EA	2	IC 1,2
2	1540-A00-0300-0	NUT (HEX)	M3*0.5	EA	2	IC 1,2
3	6100-PAP-0701-0	MAIN PCB	6100-PAP-0701-0	EA	1	
4	6220-100-7805-0	IC(REGULATOR)	LM7805	EA	1	IC 2
5	6220-100-7810-0	IC(REGULATOR)	LM7810	EA	1	IC 1
NO	MAT'L NEW CODE	PART NAME	SPECIFICATION	UNIT	Q'TY	LOCATION

ASS'Y ANALOG MODULE						
1	1050-A00-0008-0	SHIELD CASE (CAM)	60.2*37*19*1t	EA	1	
2	1510-A00-0236-0	TAPPING SCREW-1	2.3*6	EA	1	
3	1810-A00-0013-0	ANALOG PLATE	43*14.5(CAM)	EA	1	
4	6121-PMD-0100-0	ANALOG PCB	6144-A01-0100	EA	1	
5	6236-ISO-4011-0	IC(D-MOS-GATE)	UPD4011BG	EA	1	
6	6236-ISO-4066-0	IC(ANALOG SW)	UPD4066BG	EA	1	
7	6240-ISO-0177-0	IC(OP-AMP)	OP-177GS	EA	1	
8	6240-ISO-0040-0	IC(OP-AMP)	UPC4072G2	EA	2	
9	6281-I00-1504-0	CHIP TRANSISTOR	KTA1504 SY	EA	3	
10	6294-ICP-0181-0	SWITCHING DIODE	KDS 181 (SMD)	EA	1	
11	6527-ROD-0101-0	CHIP RESISTOR 1/10W	RR1220P-101D(100Ω)	EA	2	
12	6527-ROD-0222-0	CHIP RESISTOR 1/10W	RR1220P-222D(2.2K)	EA	1	
13	6527-ROD-0103-0	CHIP RESISTOR 1/10W	RR1220P-103(10K)	EA	6	
14	6527-ROD-4992-0	CHIP RESISTOR 1/10W	RR1220P-4992D(49.9K)	EA	2	
15	6527-ROD-0104-0	CHIP RESISTOR 1/10W	RR1220P-104D(100K)	EA	4	
16	6540-RPR-11K5-0	PRECISION RESISTOR	FLAY 11K500B	EA	2	
17	6550-RM0-0400-0	NETWORK RESISTOR	2B-35-ME16(1K/10K)	EA	1	
18	6702-CAP-0106-0	CHIP TANTAL	10MCS 106 MB TER	EA	1	
19	6702-CAP-0685-0	CHIP TANTAL	16MCS 685 MB TER	EA	2	
20	6800-F00-0220-0	EMI FILTER	220PF(TDK)	EA	2	
21	6712-CHP-0104-0	CHIP CONDENSER	CL21F 104 MBNC	EA	10	
22	6720-CAP-0105-A	POLYESTER CONDENSER	1 μF/63V J RATE BOX-TYPE	EA	1	
23	6720-CAP-0474-A	POLYESTER CONDENSER	0.47 μF/63V J RATE BOX TYPE	EA	3	
24	6722-CAP-0104-0	P.P CONDENSER	DTW-104J/100V J	EA	1	
25	7810-C00-9294-0	CONNECTOR	929400-40(MALE)	EA	0.275	

3

ASS'Y DIGITAL MODULE						
1	1050-A00-0009-0	SHIELD CASE (CDM)	60.2*37*19*1t	EA	1	
2	1510-A00-0236-0	TAPPING SCREW -1	2.3*6	EA	1	
3	1810-A00-0015-0	DIGITAL PLATE	43*14.5	EA	1	
4	6101-PMD-0010-0	DIGITAL PCB	6101-PMD-0010-0	EA	1	AP-1
5	6200-IPU-0154-0	IC	MSM83C154H-D24GS-VIK	EA	1	
6	6205-ISO-2416-0	IC (EEP-ROM)	X24164S-C7000	EA	1	
7	6210-ISO-6052-0	IC (RESET)	H6052 V1 (SOT223)	EA	1	
8	6224-ISO-1631-0	IC (FIP-DRIVER)	UPD16310GF-3L9	EA	1	
9	6527-ROD-0101-0	CHIP RESISTOR 1/10W	RR1220P-101D (100Ω)	EA	4	
10	6527-ROD-0222-0	CHIP RESISTOR 1/10W	RR1220P-222D(2.2K)	EA	6	
11	6702-CAP-0106-0	CHIP TANTAL	10MCS 106 MB	EA	1	
12	6712-CAP-0180-0	CHIP CAPACITOR	18PF/50V (CL21C180J)	EA	2	
13	6281-I00-1504-0	CHIP TRANSISTOR	KTA1504 SY	EA	1	
14	6712-CHP-0104-0	CHIP CONDENSER	CL21F 104 MBNC	EA	4	
15	7010-ZM0-1105-A	CRYSTAL	11.0592 NHZ(ATS-49/U)	EA	1	

NO	MAT'L NEW CODE	PART NAME	SPECIFICATION	UNIT	Q'TY	LOCATION
16	7810-C00-9294-0	CONNECTOR	929400-40 (MALE)	EA	1.2	
ASS'Y BODY						
1	2620-A00-0017-0	CONNECTOR HOLE COVER	30*20*6.6t	EA	1	
2	1050-A00-0002-0	SELECT S/W COVER	AL 30*13*0.5t	EA	1	
3	1100-A00-0001-0	BODY	345*320*31	EA	1	
4	1100-A00-0024-0	PLATFORM	332*181.5*30.5	EA	1	
5	1512-A00-0420-0	TAPPING SCREW (PH)-2	4*20	EA	3	
6	1502-A00-0308-0	MACHINE SCREW (PH)	M3*8	EA	2	
7	1502-A00-0406-0	MACHINE SCREW (PH)	M4*6	EA	2	
8	1503-A00-0408-0	MACHINE SCREW (WPH)	M4*8	EA	4	
9	1502-A00-0420-0	MACHINE SCREW (PH)	M4*20	EA	1	
10	1502-A00-0425-0	MACHINE SCREW (PH)	M4*25	EA	1	
11	1030-A00-0047-0	CONNECTOR BRACKET	SPC 1.5t, 65*26	EA	1	
12	2600-A00-0004-0	PLATFORM RUBBER	NBR 11*18*23-BLACK	EA	4	
13	1520-A00-0520-0	HEXAGON BOLT	M5*20	EA	4	
14	1530-MSU-0615-0	WRENCH BOLT(WA)	M6*20-SUS	EA	2	
15	1530-MSU-0625-0	WRENCH BOLT	M6*25-SUS	EA	2	
16	1540-A00-0500-0	NUT (HEX)	M5*0.8	EA	4	
17	2001-A00-0053-0	FOOT	S8*1.25*30	EA	4	
18	2002-A00-0001-0	W/L GAUGE ASS'Y	Φ19*Φ21*14.5-IVORY	EA	1	
19	7502-PAP-0220-0	POWER TRANS (48)	220V/50-60Hz(AP)	EA	1	
20	7620-S00-0160-0	FUSE	S504-160mA/250V	EA	1	
21	7630-S00-0020-A	FUSE HOLDER	FH-20(Φ13)	EA	1	
22	7560-PAC-0003-0	AC CORD (A)	7A750V 2P 2.5M	EA	1	
23	7642-S00-0060-0	METAL CLAMP	6N	EA	2	
24	7642-S00-0007-0	CABLE CLAMP	DA-06N	EA	1	
25	7642-S00-0004-0	CABLE CLAMP	DA-4N	EA	1	
26	7640-S00-0604-0	CORD STOPPER	SR-6N-4	EA	1	
27	7702-G00-0006-0	PCB SUPPORT	6N-(T)	EA	5	
ASS'Y UPPER COVER						
28	1000-A00-0012-0	TRAY	345*223*15*0.9t	EA	1	
29	1502-A00-0430-0	MACHINE SCREW (PH)	M4*30	EA	2	
30	1512-A00-0420-0	TAPPING SCREW (PH)-2	4*20	EA	3	
NO	MAT'L NEW CODE	PART NAME	SPECIFICATION	UNIT	Q'TY	LOCATION
39	2002-A00-0002-0	SPAN HOLE COVER	NYNON #6 23*10*16.5	EA	1	
ASS'Y C/T BOX						
1	7620-S00-0160-0	FUSE	S504-160mA/250V	EA	1	
2	9002-A00-0069-0	MANUAL	AD TYPE	EA	1	
3	9301-A00-0003-0	MANUAL POLY BAG	170*250*0.05t	EA	1	
4	9304-A00-0005-0	SET POLY BAG	580*450*0.05t	EA	2	
5	9400-A00-0040-0	SILICAGEL	10g	EA	2	
6	9105-AC1-0001-0	C/T BOX	505*385*205	EA	1	
7	9104-AP0-0004-0	PAD	495*375	EA	1	
8	9203-AS0-0004-0	STYROFOAM BOX-L	380*170*220	EA	1	
9	9203-AS0-0005-0	STYROFOAM BOX-R	380*170*220	EA	1	
10	9105-AD3-0001-0	C/T BOX-2	525*405*450	EA	1	
11	9300-A00-0001-0	FUSE POLY BAG	50*60*0.05t(ACCY)	EA	1	
ASS'Y LOAD CELL						
				EA	1	

CHAPTER-VIII APPENDIX-I

A. INPUT CODES FOR THE DIGITAL MODULE

A.1 THE ALTERNATIVE KEY FUNCTIONS

A.1.1 In this mode, the functions of three key are converted as below Fig. 1.

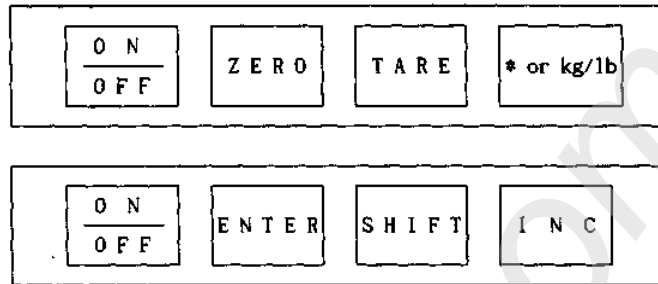

Fig. 1

A. 1.2 "INC" -> This key does increase the number by one at current number. And also any numeral can be increased from "0" to "F" (hexadecimal)
 A. 1.3 "SHIFT" -> This key shifts to the next numeric digit.
 A. 1.4 "ENTER" -> This key saves the current code or revised code.

A.2 INPUT FOR WEIGHING CONDITION CODES

A.2.1 Set the scale to the calibration mode. A.2.2 Press the "ON/OFF" key (MODE 1).
 -> The display is shown "C-Set" and then "I-XX". A.2.3 Enter each weighing condition code. Refer to Table 1 through Table 4 under 1 / 3,000 of external resolution.

THE CODES FOR HOLD VERSION

STEP	2.5kg	3 kg	6 kg	15 kg	30 kg	6 lbs	15 lbs	30 lbs	60 lbs
1	8 0	8 1	8 1	8 1	8 1	8 1	8 1	8 1	8 1
2	5 2	2 0	2 1	2 2	2 0	2 1	2 2	2 3	2 1
3	4 0	4 0	4 0	4 0	4 0	4 0	4 0	4 0	4 0
4	0 1	2 3	2 3	2 3	2 2	A 3	A 3	A 2	A 2

THE CODES FOR
STANDARD
VERSION

Table 1

STEP	2.5 kg	3 kg	6 kg	15 kg	30 kg	6 lbs	15 lbs	30 lbs	60 lbs
1	8 0	8 1	8 1	8 1	8 1	8 1	8 1	8 1	8 1
2	5 2	2 0	2 1	2 2	2 0	2 1	2 2	2 0	2 1
3	4 1	4 1	4 1	4 1	4 1	4 1	4 1	4 1	4 1
4	0 1	2 3	2 3	2 3	2 2	A 3	A 3	A 2	A 2

THE CODES FOR PRINTER VERSION

'NOTE : This printer interface feature is only available with CAS TOP PRINTER P-202

S T E P	2.5 kg	3 kg	6 kg	15 kg	30 kg	6 lbs	15 lbs	30 lbs	60 lbs
1	8 0	8 1	8 1	8 1	8 1	8 1	8 1	8 1	8 1
2	5 2	2 0	2 1	2 2	2 0	2 1	2 2	2 0	2 1
3	4 2	4 2	4 2	4 2	4 2	4 2	4 2	4 2	4 2
4	0 1	2 3	2 3	2 3	2 2	A 3	A 3	A 2	A 2

Table 3

THE CODES FOR kg/lb VERSION

S T E P	2.5 kg	3 kg	6 kg	15 kg	30 kg	6 lbs	15 lbs	30 lbs	60 lbs
1	8 0	8 1	8 1	8 1	8 1	8 1	8 1	8 1	8 1
2	5 2	2 0	2 1	2 2	2 0	2 1	2 2	2 0	2 1
3	4 3	4 3	4 3	4 3	4 3	4 3	4 3	4 3	4 3
4	0 1	2 3	2 3	2 3	2 2	A 3	A 3	A 2	A 2

Table 3

A.3 THE SPAN CALIBRATION

Refer to SPAN CALIBRATION FROM REPAIR in chapter-II.