

Road Weigher

MODEL : RW-2601P

SERVICE'S MANUAL

(kg/lb Version)

CAS

Contents

1. Introduction	2
2. Feature	3
3. Technical Specification	3
4. Front Panel Description	5
5. Test Mode	8
6. Set Mode	12
7. Calibration Mode	15
8. Garvity Mode	19
9. Error Message and Trouble Shooting	20
10. Part arrange	
11. Schematic Diagram	
12. Part List	
13. Explode View	

1. Introduction

We greatly appreciate your purchase of CAS Road Weigher, which is used for displaying the value of weight loaded on each shaft of vehicle. These goods have hold excellent performance and splendid properties through strike tests as well as devoting ourselves under severe quality management.

Also, it is programmed on the basic of the user's convenience help display functions to be used easily.

Before using road Weigher, it is recommended to read this manual carefully and to apply the function application fully.

Cautions

Do not press the keys hardly, for the keys are in operation with soft touch.

Do not use ignitable material for cleaning.

Avoid sudden temperature change.

Do not install Road Weigher in a place with high voltage and excessive electrical noises.

Keep it in dry place.

Do not use at the place with excessive electrical noises and vibration.

2. Features

- Up to 6 axle(P/F) scales
- Compact size & light weight Box type
- Built in inner clock for date/time print
- Built in Printer(serial printer)
- Built in Battery Charger & Large capacity Battery
(6V/10A x 2 EA)

3. Technical Specification

Overview



Dimension

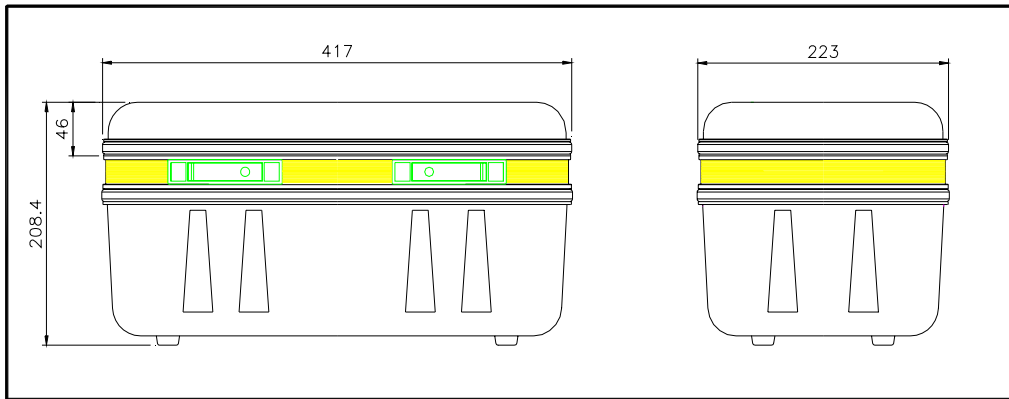

Specification

Model Name	RW-2601P	RW-Printer Box	Accessory Box
Operating Power	- Inner Battery Operation. (DC6V)		Cable, AC Cord, Adaptor,
Power Source	AC 110/220V, 50/60 Hz (For Battery Charger)		
Display Type	LCD	Built In Printer without Display	
Display Designators	Stable, Zero, kg/lb		
Product Weight	9.2 kg	6.5 kg	3.5 kg

4. Front Panel Description

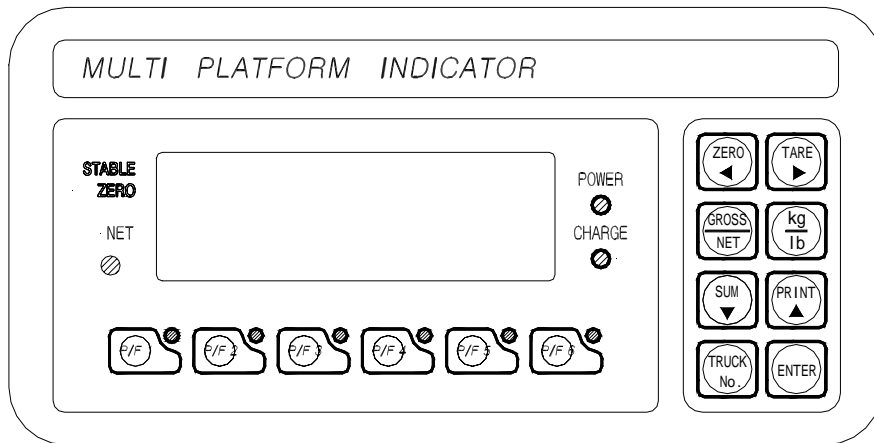

Display lamp

STABLE lamp : Turn on when the weight is stable.

ZERO lamp : Turn on when the current weight is 0 kg(0 lb).

lb/kg : Turn on when the weight unit is lb or kg.

Key Usage



ZERO key : Used to return the display to the center of ZERO when the platform is empty.



kg/lb key : Toggles between lb and kg units.
(only It is used in the USA Version)



SUM key : Used to print sum total weights.



PRINT key : Used to print the current weight.



TRUCK No. key : Used to input the number plate of vehicle which is used to weigh.

Only you can input number within five digits.



ENTER key : Used to store current condition and exit in CALIBRATION, TEST, SET mode.



P/F1 key : Used to display the weight which is connected to Platform 1.



P/F2 key : Used to display the weight which is connected to Platform 2.



P/F3 key : Used to display the weight which is connected to Platform 3.



P/F4 key : Used to display the weight which is connected to Platform 4.

 P/F5 key : Used to display the weight which is connected to Platform 5.

 P/F6 key: Used to display the weight which is connected to Platform 6.



*** How to enter TEST mode**

Turn on the Power while pressing the  key, and TEST mode starts.

*** How to enter SET mode**

Turn on the Power while pressing the  key, and SET mode starts.

*** How to enter CAL mode**

Turn on the Power while pressing the  key and press  key,
and CAL mode starts.

Power Part

Serial Port(9 pin) :

Send the weighing data to P.C or Sub-display

Fuse Holder

A C Cord :

To charge the battery



Power ON/OFF switch

5. Test Mode

(1) How to enter

Press the "ON/OFF" key while pressing the  key, and TEST menu starts.

(2) Available keys

-  Key : Change the set value.
Used to increase the set value + 1.
-  Key : Change the digit of the set value.
Used to increase the set value $\times 10$.
-  Key : Move to the next menu.

(3) Test Menu(TEST 1 - TEST 5)

- Test 1 : Key Test
- Test 2 : LCD Display Test
- Test 3 : Load Cell Test and A/D conversion test
- Test 4 : Serial Interface / Printer Test(RS-232)

TEST 1

FUNCTION : Key test		
Key	Display	Description
ENTER key : Move to the next menu. Other key : Perform test.	tEst1 Key number ex) In case of Zero key 1	TEST 1 condition. Press the key to be test and the No of key mode should be identify with code of key. If you press Enter key, it will be moved to test 2.

< Key List >

Key	Code Number	Key	Code Number
P/F 1	03	Tare	05
P/F 2	07	Gross/Net	09
P/F 3	11	kg/lb	13
P/F 4	15	Sum	02
P/F 5	04	Print	06
P/F 6	08	Truck No.	10
Zero	01	Enter	14

TEST 2

FUNCTION : LCD display test		
Key	Display	Description
Enter : Move to the next menu Other Keys : Perform Test	tEst 2 8.8.8.8.8 ■ ■ ■ ■ ■	TEST 2 condition. TEST 2 is automatically performed. After this test completing, it will be moved to test3 automatically.

Ref 1. Program is automatically shifted to test 3 after completing Test 2.

TEST 3

FUNCTION : Load cell test and A/D conversion		
Key	Display	Description
Enter : Move to the next menu. Other Keys : Perform Test.	tEst 3 Digital value of current weight in PF which you set. ex) 1 5 0 0	TEST 3 condition Display digital value of current weight. This value means converted digital value under actual condition. If you press Enter key, it will be moved to test 4.

Ref 1. A/D converter test is automatically completed by displaying converted digital value of current weight.

Ref 2. L/C test is also completed by loading the weight on the platform. Check whether digital value is changing.

If the digital value is fixed or zero is displayed, please check the connection of the load cell.

TEST 4

FUNCTION : Serial Interface / Printer test		
Key	Display	Description
ENTER: Exit from the Test Mode Other Keys : Perform Test	tEst 4 - - - - GOOD 2601P	Test 4 condition Press Enter key. It will be moved to Normal Mode after test mode.

Ref 1. Perform test only when the printer connection are installed.

Ref 2. "GOOD" message is displayed if the printer connection and specification is done correctly. If or not, "ERR 6" message is displayed.

Ref 3. The test output format of printer is as the follows.

TEST OK

If you press the Enter key, it will be returned to NORMAL MODE.
However, only when it is connected with printer, this test can be performed.

*** PRINTER FORM ***

1999. 3. 1	10:15:20
WEIGHT 1	1200 kg
WEIGHT 2	1200 kg
WEIGHT 3	1100 kg
WEIGHT 4	1100 kg

TOTAL	4600 kg

6. Set Mode

(1) How to enter

Press the "ON/OFF" key while pressing the  key, and TEST menu starts.

(2) Available keys

 Key : Change the set value.
Used to increase the set value + 1.

 Key : Change the digit of the set value.
Used to increase the set value $\times 10$.

 Key : Move to the next menu.

(3) Set Menu(F01 - F14)

F01 : Select Primary Base Unit (kg/lb)-U.S.A version.

F04 : Digital Filter Function.

F08 : Back Light Selection

F13 : Quantity of Scales (P/F, Axle Scale)

F14 : Select Option Clock.

Select Primary Base-unit		
F01	0	Primary unit is kg
	1	Primary unit is lb

Digital Filter Function			
F04	1	1 : Less Vibration	Adjust the set value according to the condition.
	9	9 : Much Vibration	

Select the Back-Light Usage		
F08	0	Manual Back Light
	1	Automatic Back Light



Quantity of Scales		
F13	1	one scale
	2	two scales
	3	three scales
	4	four scales
	5	five scales
	6	six scales

Select Option Clock		
F14	0	Not used
	1	Used



Change the Date/Time (Ex. 2000/12/11 13:10:01)		
	Display	Description
: Increase of no. : Shift of digit. Enter : Store and move to the next menu.	C1 00	YEAR : 00
	C2 12	MONTH : 12
	C3 11	DAY : 11
	C4 13	HOUR : 13
	C5 10	MINUTE : 10
	C6 01	SECOND : 01

7. Calibration Mode

(1) How to enter

Turn on the Power while pressing the  key, and then press  key, and press Enter key as soon as you selecting the number of platform. If you don't set the number of platform, it will automatically be moved to Normal Mode. F13 should be set before entering to CAL mode.

(2) Available keys

-  Key : Change the set value.
Used to increase the set value + 1.
-  Key : Change the digit of the set value.
Used to increase the set value $\times 10$.
-  Key : Move to the next menu.

(3) Calibration Menu(CAL 1 - CAL 5)

- CAL 1 : Maximum Capacity Setting
- CAL 2 : Minimum Division Setting
- CAL 3 : Setting Weight
- CAL 4 : Zero Calibration
- CAL 5 : Span Calibration

CAL 1

FUNCTION : Maximum Capacity Set		
RANGE ---> 1 ~ 99,999 kg/lb		
Key	Display	Description
: Increase of no. : Shift of digit. ENTER : Store and move into next menu.	ti.03 CAL 1 10000 Maximum Capacity Value	Program version CAL 1 condition 10000 kg/lb

Ref 1. The maximum capacity means the maximum weight that scale can measure.

Ref 2. Do not input the resolution, there is no need to input the resolution which is automatically calculated.

Ref 3. If you press Enter key, it will be moved to CAL 2.

CAL 2

FUNCTION : Minimum Division Set		
RANGE ---> 0.0005 ~ 100 kg/lb		
Key	Display	Description
: Input the next division. ENTER : Store and move into next menu	CAL 2 0.01 Minimum Division Value	CAL 2 condition 0.01 kg/lb

Ref 1. The minimum division means the value of one division.

Ref 2. External resolution is obtained by division the min. division by the maximum capacity. Set the resolution to be within 1/10,000.

Ref 3. If you press Enter key, it will be moved to CAL 3.

CAL 3

FUNCTION : Setting Weight In Span Calibration		
RANGE ---> 1 99,999 kg/lb		
Key	Display	Description
: Increase of no. : Shift of digit ENTER :Store and move to the next menu.	CAL 3 Maximum capacity of CAL 1 (ex:10000) Setting weight (ex: 100)	CAL 3 condition 10000 kg/lb 100 kg/lb

Ref 1. The weight shall be within the range of 1 % ~ 100 % of maximum weight.

Ref 2. If the Setting Weight is under the 1% of the Maximum Capacity,
 Error message ("ERR 22") will occur.

Ref 3. If the Setting Weight over the Maximum Capacity,
 Error message ("ERR 23") will occur.

Ref 4. If you press Enter key, it will be moved to CAL 4.

CAL 4

FUNCTION : Zero Calibration Function		
Key	Display	Description
ENTER: Zero calibration and move into next menu.	CAL 4 UnLOAD A/D value - - - - - GOOD	CAL 4 condition Unload the tray and press Enter key. Display A/D Value. Press Enter key. Under zero calibration Zero calibration is completed. The program moves into Span calibration automatically.

- Ref 1. If Zero calibration is done without any error, GOOD message is displayed ,and program automatically moves to CAL 5.
- Ref 2. If the zero value is too high, ERROR message (ERR 26) is displayed.
- Ref 3. Zero calibration can be done independently. If you press ZERO key instead of Enter key, zero calibration will perform.
After that, it will be moved to SAVE & EXIT mode.

CAL 5

FUNCTION : Span Calibration Function		
Key	Display	Description
ENTER: Span calibration and Move to the next menu.	CAL 5	CAL 5 Condition
	LOAD	Load the weight which was set in CAL 3.
	Setting weight	It is displayed the setting weight. And then, press Enter key.
	- - - - -	Under span calibration.
	GOOD	Span calibration is completed. Check whether the displayed weight is same with setting weight.
	Save	Calibration is completed. Under this condition, release the load. Press the "ENTER" key to save the value.

- Ref 1. If Span calibration is done without any error, GOOD message is displayed
The weight of setting weight is displayed on Display screen.
Check the weight.
- Ref 2. If the span is low, Error message (ERR 24) is displayed.
Calibrate with lower resolution.
- Ref 3. After setting the exact value, remove the setting weight and Press the "ENTER" key to save the value.
- Ref 4. In case of setting F13, it can be moved to another Platform.
If all of platform is finished, it will be moved to Normal Mode.

8. Gravity compensation

(1) HOW TO ENTER

Turn on the Power while pressing the  key, and then press  key.

(2) AVAILABLE KEYS

 Key : Move to the left by 1 place of the set value.

 Key : Increase the first place set value to 1

 Key : Move into next menu.

FUNCTION : Gravity setting		
RANGE ---> 9700 9900		
KEY	LCD DISPLAY	DESCRIPTION
: Increase of no. : Shift of digit LIGHT : Store and move into next menu	G R A V 1	Gravity constant in the calibration
	9798	it means 9.798 m/s ²
	GRAV2	Gravity constant in the work place
	9812	it means 9.812 m/s ²

9. Error message and Trouble shooting

Err 02

Reason

Load cell connection failure or error in A/D conversion part.

Trouble shooting

Check the load cell connector to see if the polarity of signal is reversed.

Err 06

Reason

Error in printer connection

Trouble shooting

Check with printer connector

If there is no problem with printer connector, please request A/S to head office.

Err 13

Reason

The zero range deviates from the set range.

Trouble shooting

Confirm that there is nothing on the weighing platform.

If there is nothing exist, do calibration in CAL mode.

Over

Reason

The weight on platform is too heavy to be measured.

Trouble shooting

Do not load cell item exceeds the maximum tolerance.

If the load cell is damaged, the load cell should be replaced.

Err 21

Reason

The resolution is set to be exceeded the limit 1/10,000.

Trouble shooting

Lower the resolution.

The resolution = allowed weight/one division

Modify the allowed weight in CAL1 or modify the division in CAL2 so that the resolution should be below 1/10,000.

Err 22

Reason

The weight for span calibration is set to be lower than 10 % of the maximum capacity of the scale.

Trouble shooting

Set the weight for span calibration in CAL3 to be more than 10% of the maximum capacity.

Err 23

Reason

The weight for span calibration is set to be exceeded 100 % of the maximum capacity of the scale.

Trouble shooting

Set the weight for span calibration to be within the maximum capacity of the scale in CAL 1.

Err 24

Reason

The load cell output is too small at SPAN calibration.

Trouble shooting

Setting of current resolution is not possible due to the error in load cell. Proceed calibration again with less resolution.

Load cell Sense Voltage for 5V Excitation Voltage	Recommended Resolution
2 mV	1/1,000
4 mV	1/2,000
10 mV	1/5,000

Err 25

Reason

The load cell output is too large at SPAN calibration.

Trouble shooting

Setting of current resolution is not possible due to the error in load cell. Proceed calibration again with less resolution.

Err 26

Reason

The load cell output is too large at ZERO calibration.

Trouble shooting

Check whether the platform empty.

Proceed calibration again after checking in A/D TEST mode.

10. Part Arrangement

11. Schematic Diagram

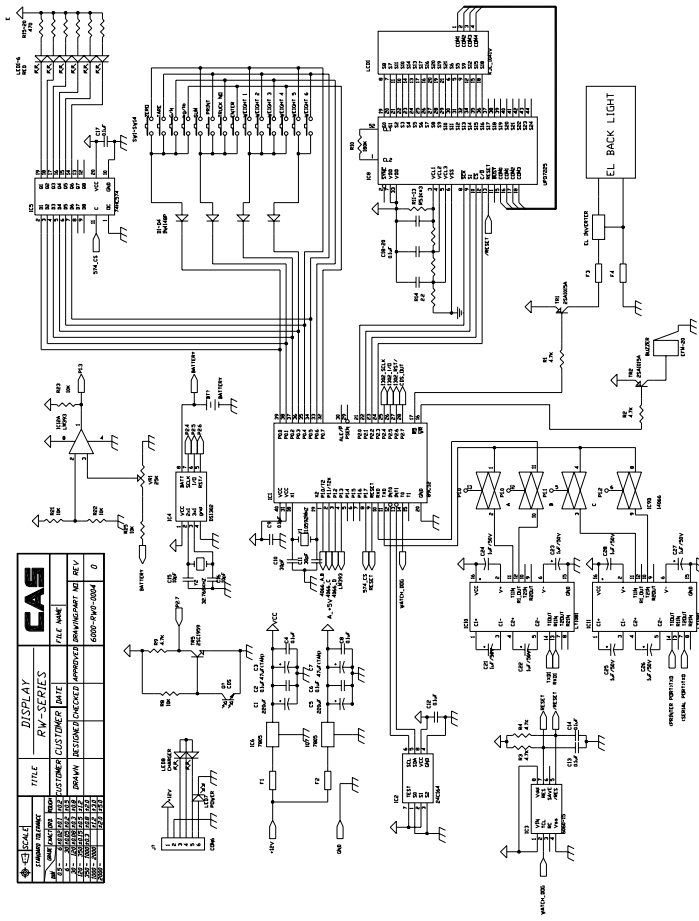

CAS	
DISPLAY	RW-SERIES
FILE NAME	CUSTOMER CUSTOMER DATE
REV	REVISIONS CHECKED APPROVED
0	6000-1000-0004

12.Part List

